



Closure Technical Specification

Aluminium Division

Sheet code : 106.03

Denomination: Pilfer Proof Closure 31.5x18,5 _ Vinegar pourer_std

Closure Features

Cap		Liner		litho code	Offset code
Material	Aluminium	Vinegar pourer		245.800	-
Weight without liner	1,37 g ±5%	Material	peld		
Thickness	0.21±0.01 mm.	Weight	Gr. 3,5		
Diameter	31.5 mm				
Height	18,5 mm				

Printing Features

Internal		External	
Varnish	Epoxy - Polyester	External Decoration	Vinyl-Polyester
		Ink	Polyester

Packaging Features

Packing		Packaging	
Units per carton	4300 units	Pallet	800 x 1200 mm
Carton measurements	594x382x377 mm.	Cartons per pallet	20
Carton material	Triple corrugated board	External protection	Stretch Wrapping
Internal	PE a-toxic bag	Pallet identification	Label
Identification	Label		

*Laboratory values - All dimensions are subject to tolerance of ± 0.35 mm

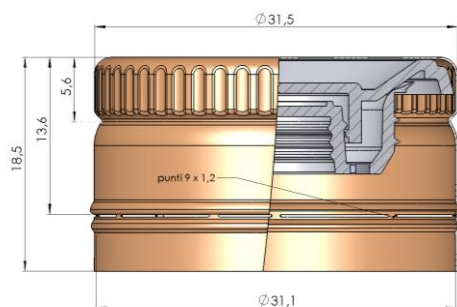

Exploded view

MATERIALE

ALU →

PELD →

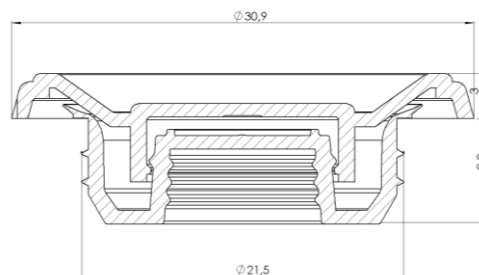

Date
19/06/2014

Designer
Anselma C.A.

Quality Ass. Manager
Vacchetto M.

Production Managers
Rainero F. / Caporaletti F.

The technical data relating to the conditions of capping below refer to laboratory tests Alplast in standard conditions. It defers to every user of the closing Alplast, correct adjustment of the capping process and packaging, taking into account variables related to the other components and machinery and equipment used. The above adjustments shall be borne by and under the responsibility of the user

Capping Conditions

Thread Roller Pressure	6-12 Kg	Vinegar pourer 31 →	Press.pad: 29,5 x 1,8mm.	Top load : 150/180 Kg
Undertuck Roller Pressure	6-12 Kg	Glass Finish : UNI 10155 ppv medium / CETIE BVPgme	*Opening torque: 6 – 18 lbf.in	

Alplast chiusure reserves the right to modify the technical information reported on this data sheet